

# HRS Series



## Heat Recovery System

- Condensate Heat Recovery
- Continuous Boiler Blow Down
- Vent Condenser



Condensate or Boiler Blow Down contains energy that can be recovered and used to preheat domestic hot water, boiler feed water, or heat a separate fluid while cooling the condensate before it is dumped down the drain or returned to the boiler.

The Cemline Heat Recovery System (HRS) works by receiving condensate or boiler blow down into the flash tank. The flash tank separates the flash steam from the condensate or boiler blow down effluent. The liquid level in the tank is controlled by the

float and thermostatic trap discharging condensate from the F&T trap to the heat exchanger to cool and recover energy from the condensate before it is dumped down the drain or returned to the boiler.

The HRS can be optionally supplied with a vent condenser to recover flash steam. Reducing the pressure of saturated condensate will cause a portion of the liquid to flash to low-pressure steam. The flash steam may contain approximately 10-40% of the energy content of the original

condensate depending upon the pressures. Most often a flash tank is used to reduce the condensate pressure whereby the flash steam is vented and the energy content is lost. This lost energy can be recovered by piping a heat exchanger in the vent of the flash tank.

The Cemline Heat Recovery System includes a flash tank, float & thermostatic trap and a condensate recovery heat exchanger. The flash tank is ASME constructed and stamped for 150 PSI working pressure.

# HRS Series



## Standard Equipment

- Flash tank
  - ASME Code Constructed National Board Registered
  - Rated for 150 psi
- Condensate Energy Recovery Heat Exchanger
  - Plate Heat Exchanger
    - Brazed Plate or Plate & Frame Style
  - Single or Double wall
- Float and Thermostatic Trap
- Isolation Ball Valve
- ASME Pressure Relief Valve
- Pressure Gauge
- Drain Valve
- Structural Support Skid

## Optional Features

- Vent Condenser
  - Shell & Tube Heat Exchanger
  - ASME Code Constructed National Board Registered
  - Rated for 150 psi
  - Tubing Options
    - Double Wall tubing
    - 90:10 Copper-Nickel tubing
    - Stainless steel tubing
  - Stainless steel coil head
  - Stainless steel shell
- Condensate Energy Recovery Heat Exchanger
  - Shell & Tube Heat Exchanger
- Sight Glass

## Sizing information required

1. Entering #/Hr of Condensate: (Range: 0 - 30,000 #/Hr)
2. Enter the Initial Pressure: (Range: 0 - 160 PSIG)
3. Enter the Flash Pressure: (Range: 0 - 15 PSIG)

4. Make up Water Inlet Temperature: (Range: 40 - 200°F)
5. Maximum Water Outlet Temperature: (Range: 40 - 200°F)

## Dimensional Data

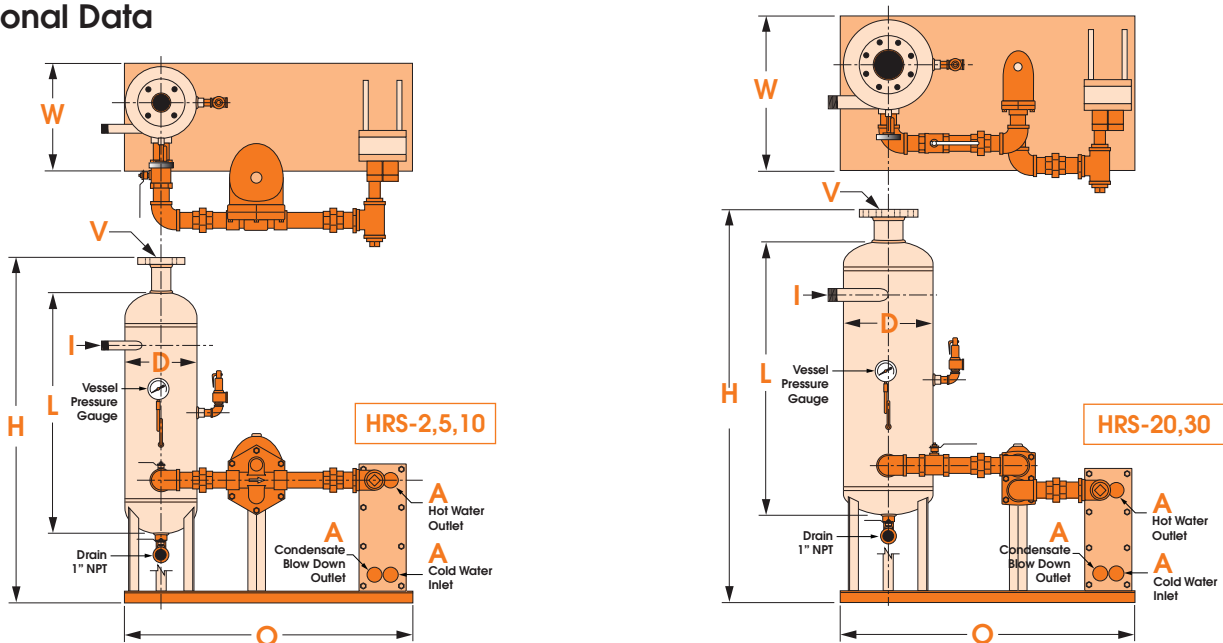

| Model Number | Make-up Capacity (#/hr) | Skid    |          |          | Vessel  |         |     |     |        |
|--------------|-------------------------|---------|----------|----------|---------|---------|-----|-----|--------|
|              |                         | W Width | O Length | H Height | V Vent  | I Inlet | D   | L   | A      |
| HRS-2        | 2,000                   | 16"     | 43"      | 51"      | 3" FLG. | 2" NPT. | 8"  | 36" | 1 1/4" |
| HRS-5        | 5,000                   | 16"     | 43"      | 51"      | 3" FLG. | 2" NPT. | 10" | 36" | 1 1/4" |
| HRS-10       | 10,000                  | 24"     | 46"      | 61"      | 4" FLG. | 3" NPT. | 14" | 42" | 1 1/4" |
| HRS-20       | 20,000                  | 24"     | 46"      | 90"      | 6" FLG. | 4" FLG. | 16" | 42" | 2"     |
| HRS-30       | 30,000                  | 30"     | 50"      | 90"      | 8" FLG. | 4" FLG. | 20" | 48" | 2"     |

©2010 Cemline Corporation All Rights Reserved.

All trademarks on this brochure are the property of Cemline Corporation, unless otherwise noted or in any other way set forth as a third party rights. Unauthorized use of these trademarks, as well as the materials presented on this site, is expressly prohibited and constitutes a violation of the intellectual property rights of Cemline Corporation.

**CEMLINE CORPORATION**

P.O. BOX 55 CHESWICK, PENNSYLVANIA 15024  
Phone: (724) 274-5430 FAX (724) 274-5448

www.cemline.com